

CEL TRANSCEIVER ICs

CEL's new ZIC2410 combines a powerful, ZigBee-compliant RF transceiver with an industry-workhorse, 8051-based 8-bit microprocessor. Ideal for applications like remote sensing, AMR/AMI, home and building automation, and security networks, the ZIC2410 can help simplify your designs, shrink their size, lower power consumption, and reduce overall system costs.

NEC RANGE EXTENSION COMPONENTS

Our NEC Power Amplifiers, LNAs and RFIC Switches are designed to integrate easily with a wide variety of 802.15.4, ZigBee and Bluetooth RF Transceiver ICs.

COMPLETE 1.8V FRONT-END SOLUTION

Need a low power solution that's big on performance? CEL also offers a complete 1.8V range extension line-up including the +20dBm output UPG2250T5N PA.

EASY-TO-USE EVALUATION BOARDS

CEL Eval Boards combine our NEC PAs and switches in a configuration that makes it easy for engineers to evaluate actual performance using their own operating transceiver. Connected between the transceiver and the antenna, the Tx signal is boosted for longer-range performance, while the Rx path from the antenna is routed directly back to the transceiver.

For higher power designs:

UPG2253T6S-ZBT-EVAL-A Eval Board

Evaluation board of our FEIC containing PA + Bypass + 2x SPDTs + Filter

UPG2250T5N-ZBT-EV-A Eval Board

Combines UPG2250T5N with UPG2214TB and UPG2179TB switches

UPG2301TQ-ZBT-EV-A Eval Board

UPG2301TQ + two UPG2214TB switches

For lower power designs:

UPG2314T5N-ZBT-EV-A Eval Board

UPG2314T5N + two UPG2214TK switches

ENGINEERING SUPPORT

CEL and its partner L.S. Research can provide the support it takes to get your designs to market. In addition, LSR offers EMC and product certification services for markets in North America, Europe and Australia.

www.cel.com

www.lsr.com

Transceiver ICs and Range Extension Components for 802.15.4/ZigBee® Applications

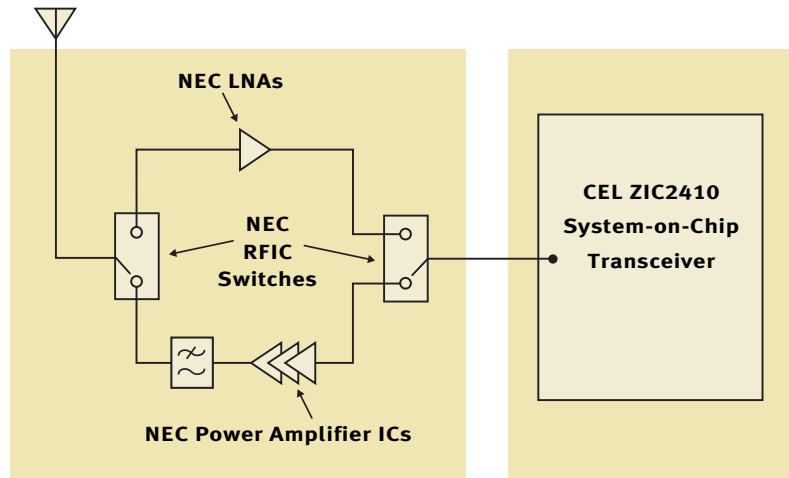

FEATURES See specifications on next page

CEL System-on-Chip Transceiver IC

ZIC2410	RF transceiver/8051 MCU, +8dBm output power, 106dB link budget, scalable data rates to 1Mbps, voice CODEC, 48 pin QFN or 72 pin VFBGA package
----------------	---

NEC GaAs MMIC POWER AMPLIFIERS AND FRONT END IC

UPG2253T6S	+19dBm P _{OUT} , 95 mA, integrated PA, Bypass, 2x SPDTs, Filter
UPG2314T5N	+20 dBm P _{OUT} , 65 mA, 20dB variable gain control
UPG2301TQ	+23 dBm P _{OUT} , 20dB variable gain control
UPG2250T5N*	1.8 to 3.3V operation, +20 dBm P _{OUT} @ 1.8V _{DD}
UPG2118K	+31.5 dBm P _{OUT} min, 52% PAE typ

NEC GaAs MMIC SPDT SWITCHES

UPG2179TB	Industry's leading medium power SPDT
UPG2214TB/TK*	1.8/3.0V operation, low insertion loss, high isolation
UPG2158T5K*	1.8/3.0V operation, miniature ultra-thin package
UPG2030TK	Low insertion loss, high isolation
UPG2012TK	Low power, single pin control voltage
UPG2015TB	Single pin control voltage, industry-standard package

NEC GaAs MMIC SP3T SWITCH

UPG2150T5L	35dB isolation between WiFi & Bluetooth ports
-------------------	---

NEC TRANSISTOR & MMIC LNAs

NESG3031M05/M14	SiGe HBT, 0.6dB noise figure, 16dB gain
NE662M04	Silicon NPN transistor, 1.3dB noise figure, 15dB gain
NE3508M04	GaAs HJ FET, 0.45dB noise figure, 14dB gain
UPC8233TK*	SiGe:C MMIC, 1.8 to 3.3V operation

* Ideal for 1.8V battery-operated designs

CEL TRANSCEIVER ICs

Part Number	Package	Operating Voltage (V)	Output Power (dBm max)	Sensitivity (dBm)	Power Consumption		
					Transmit (mA @ 0dBm)	Receive (mA)	Standby (µA)
ZIC2410 QN48/FG72	48 pin QFN or 72 pin VFBGA	1.5 to 3.3	+8	-98	QFN: 30.6 VFBGA: 29.7	33.2	0.3

NEC GaAs MMIC POWER AMPLIFIERS & FRONT END IC*

Part Number	Package	Typical Performance				
		Frequency (GHz)	Supply Voltage (V)	Output Power (dBm)	Gain Control Range (dB)	Operating Current (mA)
UPG2253T6S*	16 Pin QFN 3.0 x 3.0 x 0.75 mm	2.4 – 2.5	3.0	+19	–	95
UPG2314T5N	6 pin 1.5 x 1.5 x 0.37 mm	2.4 – 2.5	3.0	+20	20	65
UPG2301TQ	10 Pin TSON	2.4 – 2.5	3.3	+23	23	120
UPG2250T5N	6 pin 1.5 x 1.5 x 0.37 mm	2.4 – 2.5	1.5 – 3.5	+20 @ 1.8 VDD +25 @ 3.0 VDD	60	120 @ 1.8 VDD 175 @ 3.0 VDD
UPG2118K	20 Pin MLP	2.4 – 2.5	3.2	+31.5 (min)	45	900

*FEIC containing PA, Bypass, 2x SPDT, Filter

NEC GaAs SWITCH ICs

Part Number	Package	VCONT	Typical Performance		
			Insertion Loss (dB) @2.4 - 2.5 GHz	Isolation (dB) @2.4 - 2.5 GHz	Input Power (dBm) @0.1dB Comp Point
UPG2179TB	6 pin 2.0 x 2.1 x 0.9mm SOT-363	3.0 / 0 Dual	0.35	27	+29
UPG2214TB /TK	6 pin 2.0 x 2.1 x 0.9mm SOT-363, or 6 pin 1.3 x 1.5 x 0.55 mm	1.8 / 0 3.0 / 0 Dual	0.35	26	+16 @ 1.8V +23 @ 3.0V
UPG2158T5K	6 pin 1.0 x 1.0 x 0.37mm	1.8 / 0 2.7/0 Dual	0.47	17	+29
UPG2030TK	6 pin 1.3 x 1.5 x 0.55 mm	2.8 or 0	0.35	25	+27
UPG2012TB /TK	6 pin 2.0 x 2.1 x 0.9mm SOT-363, or 6 pin 1.3 x 1.5 x 0.55 mm	2.8 or 0	0.30	30 (TK) 25 (TB)	+20.5
UPG2015TB	6 pin 2.0 x 2.1 x 0.9mm SOT-363	2.8 or 0	0.35	25	+27
SP3T:					
UPG2150T5L	12 pin 2.0 x 2.0 x 0.37mm	2.85 or 0	0.50 (RF1, 2) 0.60 (RF3)	35	+31 @ 1.0dB Comp Point

NEC TRANSISTOR LNAs

Part Number	Package	Typical Performance		
		Noise Figure (dB)	Gain (dB)	Output Power P1dB (dBm)
NESG3031M05/M14	4 pin 2.5 x 2.0 x 0.6 mm M05, or 4 pin 1.0 x 1.2 x 0.5 mm M14	0.6	16 @ 2V, 6 mA	+12.5 @ 3V, 20 mA
NE662M04	4 pin 2.0 x 2.0 x 0.6 mm SOT-343	1.2	14 @ 2V, 6 mA	+11 @ 2V, 20 mA
NE3508M04	4 pin 2.0 x 2.0 x 0.6 mm SOT-343	0.74	14.8 @ 2V, 10 mA	+15.9 @ 3V, 30 mA
UPC8233TK	6 pin 1.3 x 1.5 x 0.55 mm	1.3	16.6 @ 1.8V, 3.5 mA	-4 @ 1.8V, 3.5 mA

Data Sheets for the devices can be found at www.cel.com