

**HIGH ISOLATION VOLTAGE
SINGLE TRANSISTOR TYPE
MULTI PHOTOCOUPLER SERIES**

-NEPOC Series-

DESCRIPTION

The PS2561-1 is optically coupled isolators containing a GaAs light emitting diode and an NPN silicon phototransistor.

The PS2561-1 is in a plastic DIP (Dual In-line Package) and the PS2561L-1 is lead bending type (Gull-wing) for surface mount.

The PS2561L1-1 is lead bending type for long creepage distance.

The PS2561L2-1 is lead bending type for long creepage distance (Gull-wing) for surface mount.

FEATURES

- High Isolation voltage ($BV = 5\,000\text{ Vr.m.s.}$)
- High collector to emitter voltage ($V_{CEO} = 80\text{ V}$)
- High current transfer ratio ($CTR = 200\% \text{ TYP.}$)
- High-speed switching ($t_r = 3\ \mu\text{s TYP.}$, $t_f = 5\ \mu\text{s TYP.}$)
- Ordering number of taping product: PS2561L-1-E3, E4, F3, F4, PS2561L2-1-E3, E4
- Safety standards
 - UL approved: No. E72422
 - CSA approved: No. CA 101391
 - BSI approved: No. 7112/7420
 - SEMKO approved: No. 303059, 307244
 - NEMKO approved: No. P03200272, P03200747
 - DEMKO approved: No. 312341, 312340
 - FIMKO approved: No. FI 10620, FI 11898
- DIN EN60747-5-2 (VDE0884 Part2) approved: No. 40008862 (Option)

<R>

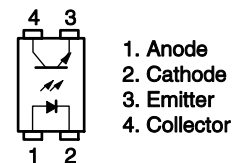
**PIN CONNECTION
(Top View)****APPLICATIONS**

- Power supply
- Telephone/FAX.
- FA/OA equipment
- Programmable logic controller

The information in this document is subject to change without notice. Before using this document, please confirm that this is the latest version.

PACKAGE DIMENSIONS (UNIT : mm)

DIP Type (New package)

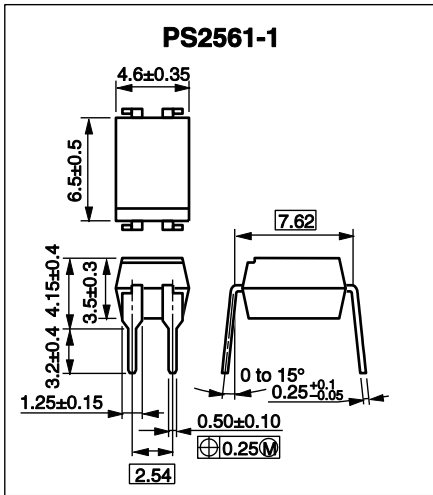

DIP Type

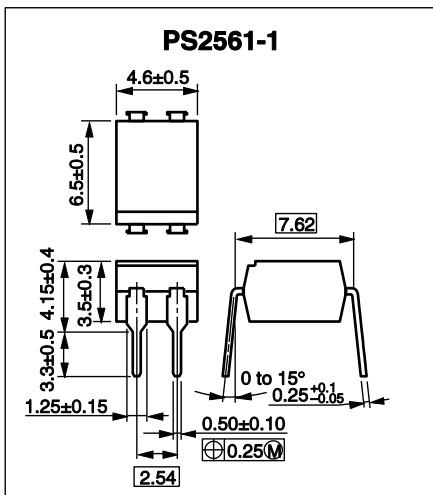

Lead Bending Type For Long Creepage Distance (New Package)

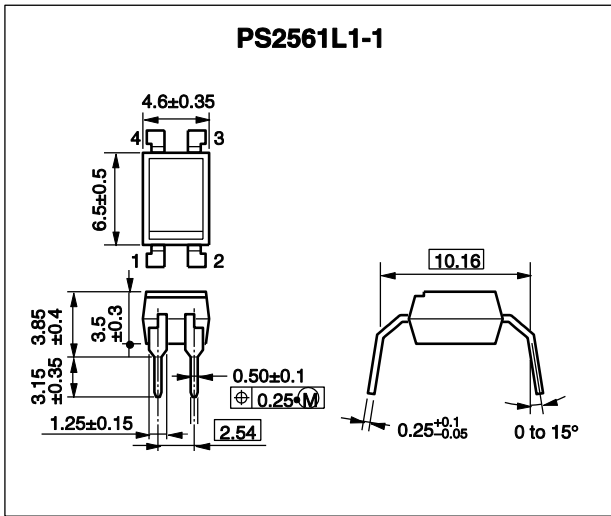

Lead Bending Type For Long Creepage Distance

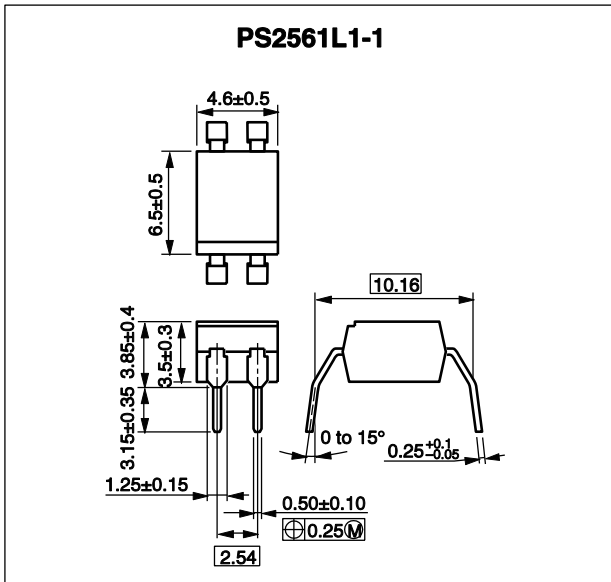

Lead Bending Type For Long Creepage Distance (Gull-Wing) (New Package)

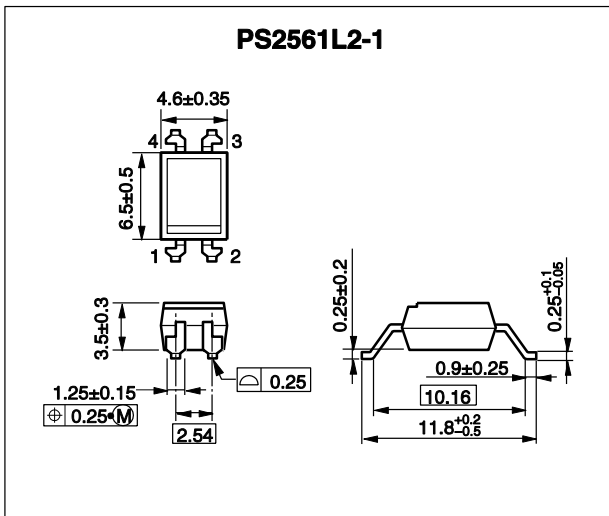

Lead Bending Type For Long Creepage Distance (Gull-Wing)

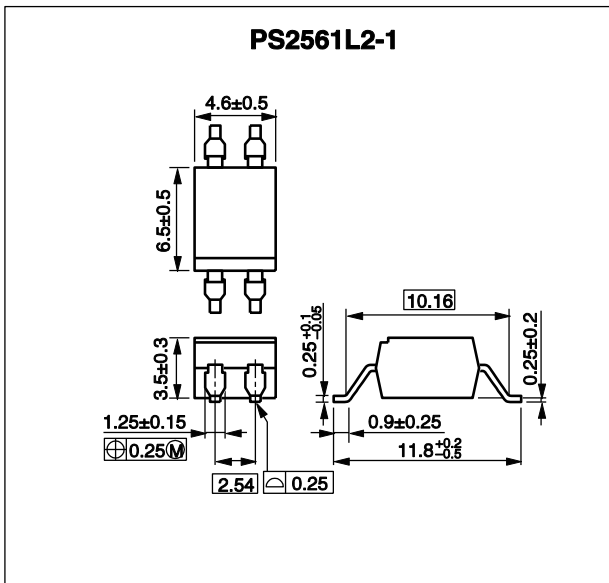

<R> MARKING EXAMPLE

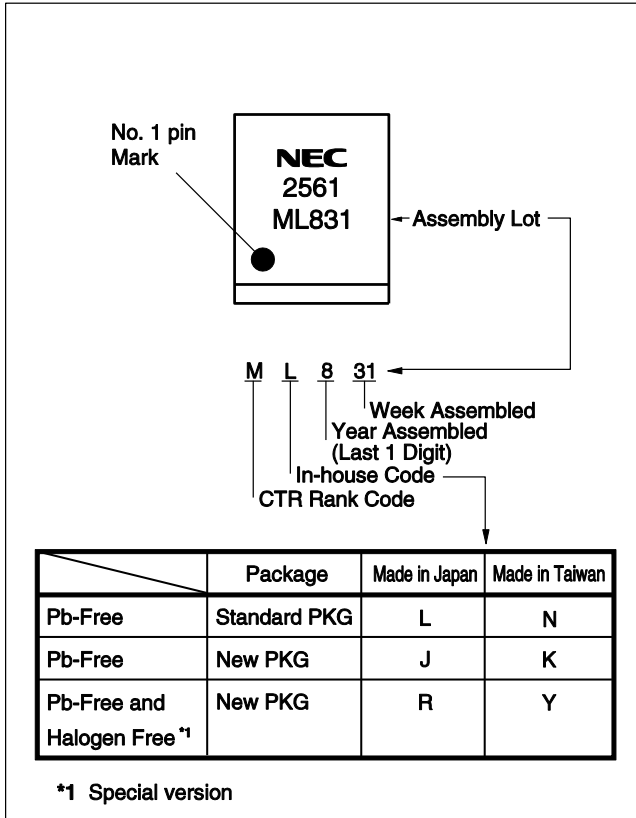

<R> **ORDERING INFORMATION**

| Part Number | Order Number | Solder Plating Specification | Packing Style | Safety Standard Approval | Application Part Number *1 |
|-----------------|--------------------|--|------------------------------|---|----------------------------|
| PS2561-1 | PS2561-1-A | Pb-Free | Magazine case 100 pcs | Standard products (UL, CSA, BSI, NEMKO, SEMKO, DEMKO, FIMKO approved) | PS2561-1 |
| PS2561L-1 | PS2561L-1-A | | | | |
| PS2561L1-1 | PS2561L1-1-A | | | | |
| PS2561L2-1 | PS2561L2-1-A | | | | |
| PS2561L-1-E3 | PS2561L-1-E3-A | | Embossed Tape 1 000 pcs/reel | | |
| PS2561L-1-E4 | PS2561L-1-E4-A | | | | |
| PS2561L-1-F3 | PS2561L-1-F3-A | | Embossed Tape 2 000 pcs/reel | | |
| PS2561L-1-F4 | PS2561L-1-F4-A | | | | |
| PS2561L2-1-E3 | PS2561L2-1-E3-A | | Embossed Tape 1 000 pcs/reel | | |
| PS2561L2-1-E4 | PS2561L2-1-E4-A | | | | |
| PS2561-1-V | PS2561-1-V-A | | Magazine case 100 pcs | DIN EN60747-5-2 (VDE0884 Part2) approved products (Option) | |
| PS2561L-1-V | PS2561L-1-V-A | | | | |
| PS2561L1-1-V | PS2561L1-1-V-A | | | | |
| PS2561L2-1-V | PS2561L2-1-V-A | | | | |
| PS2561L-1-V-E3 | PS2561L-1-V-E3-A | | Embossed Tape 1 000 pcs/reel | | |
| PS2561L-1-V-E4 | PS2561L-1-V-E4-A | | | | |
| PS2561L-1-V-F3 | PS2561L-1-V-F3-A | | Embossed Tape 2 000 pcs/reel | | |
| PS2561L-1-V-F4 | PS2561L-1-V-F4-A | | | | |
| PS2561L2-1-V-E3 | PS2561L2-1-V-E3-A | | Embossed Tape 1 000 pcs/reel | | |
| PS2561L2-1-V-E4 | PS2561L2-1-V-E4-A | | | | |
| PS2561-1 | PS2561-1Y-A | Special version (Pb-Free and Halogen Free) | Magazine case 100 pcs | Standard products (UL, CSA, BSI, NEMKO, SEMKO, DEMKO, FIMKO approved) | PS2561-1 |
| PS2561L-1 | PS2561L-1Y-A | | | | |
| PS2561L1-1 | PS2561L1-1Y-A | | | | |
| PS2561L2-1 | PS2561L2-1Y-A | | | | |
| PS2561L-1-F3 | PS2561L-1Y-F3-A | | Embossed Tape 2 000 pcs/reel | | |
| PS2561L2-1-E3 | PS2561L2-1Y-E3-A | | Embossed Tape 1 000 pcs/reel | | |
| PS2561-1-V | PS2561-1Y-V-A | | Magazine case 100 pcs | DIN EN60747-5-2 (VDE0884 Part2) approved products (Option) | |
| PS2561L-1-V | PS2561L-1Y-V-A | | | | |
| PS2561L1-1-V | PS2561L1-1Y-V-A | | | | |
| PS2561L2-1-V | PS2561L2-1Y-V-A | | | | |
| PS2561L-1-V-F3 | PS2561L-1Y-V-F3-A | | Embossed Tape 2 000 pcs/reel | | |
| PS2561L2-1-V-E3 | PS2561L2-1Y-V-E3-A | | Embossed Tape 1 000 pcs/reel | | |

*1 For the application of the Safety Standard, following part number should be used.

ABSOLUTE MAXIMUM RATINGS (T_A = 25°C, unless otherwise specified)

| Parameter | | Symbol | Ratings | Unit |
|---------------------------------|------------------------------------|---------------------|-------------|---------|
| Diode | Reverse Voltage | V _R | 6 | V |
| | Forward Current (DC) | I _F | 80 | mA |
| | Power Dissipation Derating | ΔP _D /°C | 1.5 | mW/°C |
| | Power Dissipation | P _D | 150 | mW |
| | Peak Forward Current ^{*1} | I _{FP} | 1 | A |
| Transistor | Collector to Emitter Voltage | V _{CEO} | 80 | V |
| | Emitter to Collector Voltage | V _{ECO} | 7 | V |
| | Collector Current | I _C | 50 | mA |
| | Power Dissipation Derating | ΔP _C /°C | 1.5 | mW/°C |
| | Power Dissipation | P _C | 150 | mW |
| Isolation Voltage ^{*2} | | BV | 5 000 | Vr.m.s. |
| Operating Ambient Temperature | | T _A | -55 to +100 | °C |
| Storage Temperature | | T _{stg} | -55 to +150 | °C |

*1 PW = 100 μs, Duty Cycle = 1%

*2 AC voltage for 1 minute at T_A = 25°C, RH = 60% between input and output
Pins 1-2 shorted together, 3-4 shorted together.

ELECTRICAL CHARACTERISTICS (T_A = 25°C)

| Parameter | | Symbol | Conditions | MIN. | TYP. | MAX. | Unit |
|------------|--|----------------------|---|------------------|------|------|------|
| Diode | Forward Voltage | V _F | I _F = 10 mA | | 1.17 | 1.4 | V |
| | Reverse Current | I _R | V _R = 5 V | | | 5 | μA |
| | Terminal Capacitance | C _t | V = 0 V, f = 1.0 MHz | | 50 | | pF |
| Transistor | Collector to Emitter Dark Current | I _{CEO} | V _{CE} = 80 V, I _F = 0 mA | | | 100 | nA |
| Coupled | Current Transfer Ratio (I _c /I _F) ^{*1} | CTR | I _F = 5 mA, V _{CE} = 5 V | 80 | 200 | 400 | % |
| | Collector Saturation Voltage | V _{CE(sat)} | I _F = 10 mA, I _c = 2 mA | | | 0.3 | V |
| | Isolation Resistance | R _{I-O} | V _{I-O} = 1.0 kV _{DC} | 10 ¹¹ | | | Ω |
| | Isolation Capacitance | C _{I-O} | V = 0 V, f = 1.0 MHz | | 0.5 | | pF |
| | Rise Time ^{*2} | t _r | V _{CC} = 10 V, I _c = 2 mA, R _L = 100 Ω | | 3 | | μs |
| | Fall Time ^{*2} | t _f | | | 5 | | |

***1 CTR rank**

- L : 200 to 400 (%)
- M : 80 to 240 (%)
- D : 100 to 300 (%)
- H : 80 to 160 (%)
- W : 130 to 260 (%)

<R> *2 Test circuit for switching time

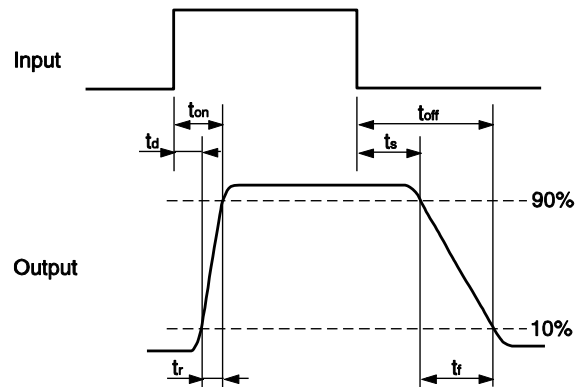
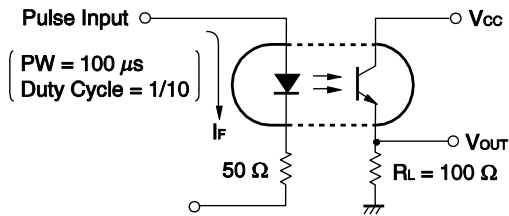

TYPICAL CHARACTERISTICS ($T_A = 25^\circ\text{C}$, unless otherwise specified)

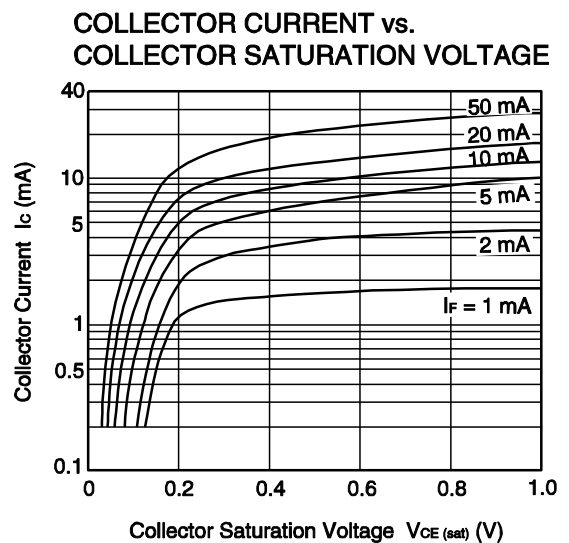
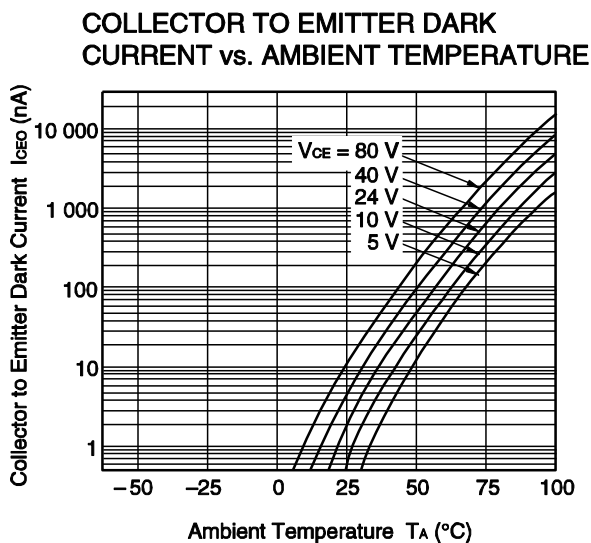
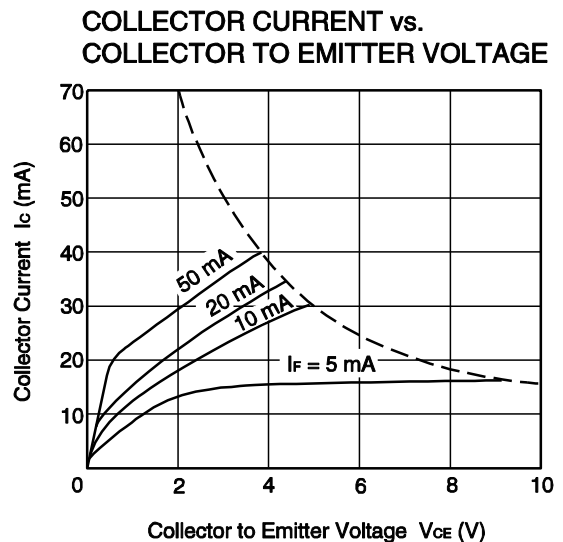
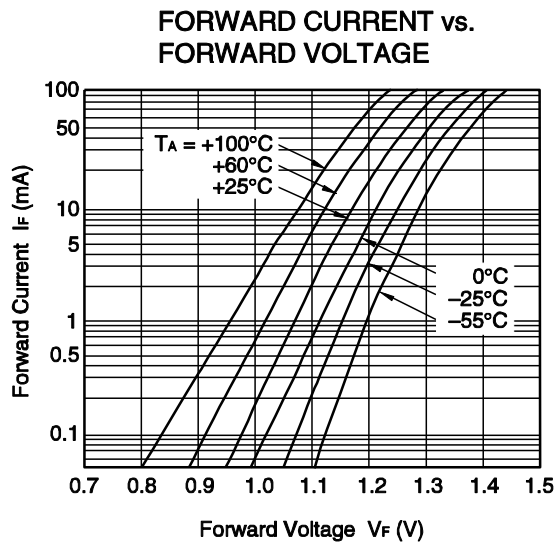
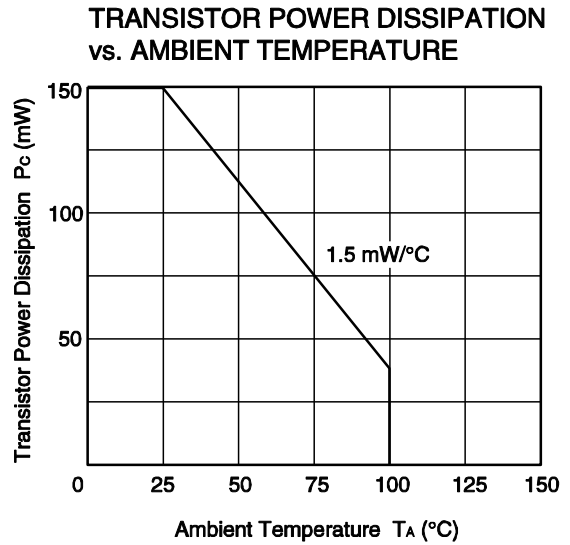
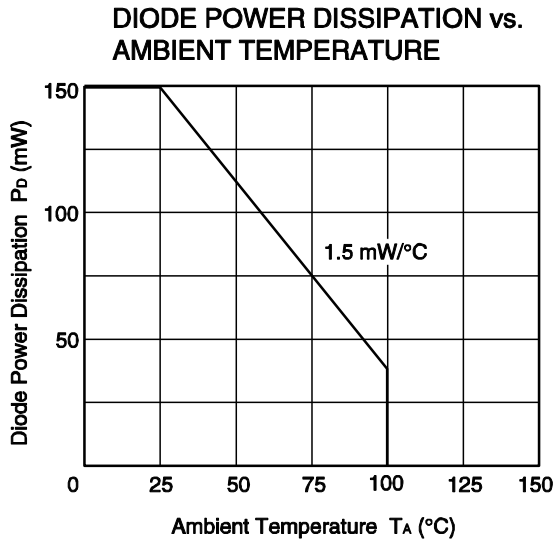

Remark The graphs indicate nominal characteristics.

NORMALIZED CURRENT TRANSFER RATIO vs. AMBIENT TEMPERATURE

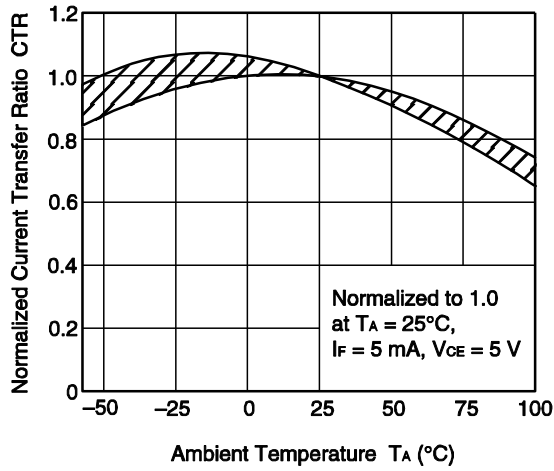

CURRENT TRANSFER RATIO vs. FORWARD CURRENT

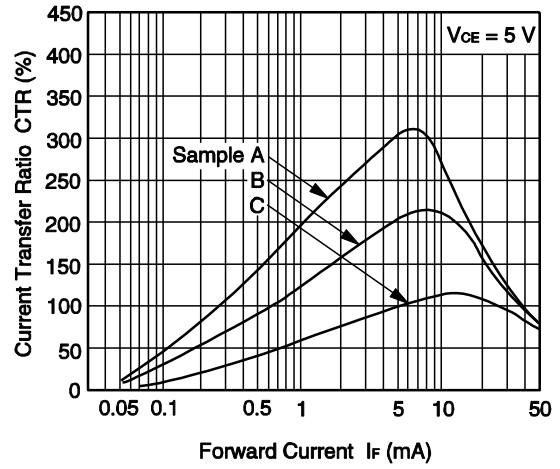

SWITCHING TIME vs. LOAD RESISTANCE

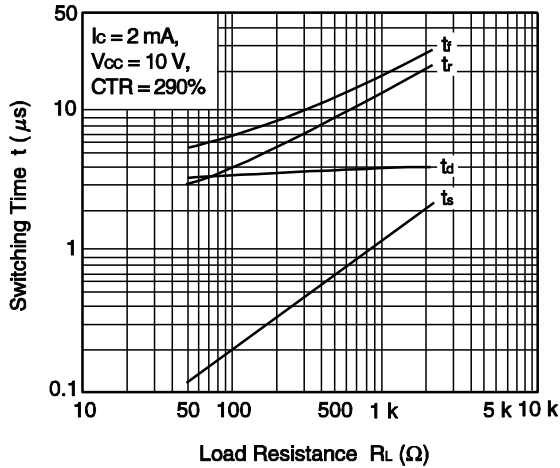

SWITCHING TIME vs. LOAD RESISTANCE

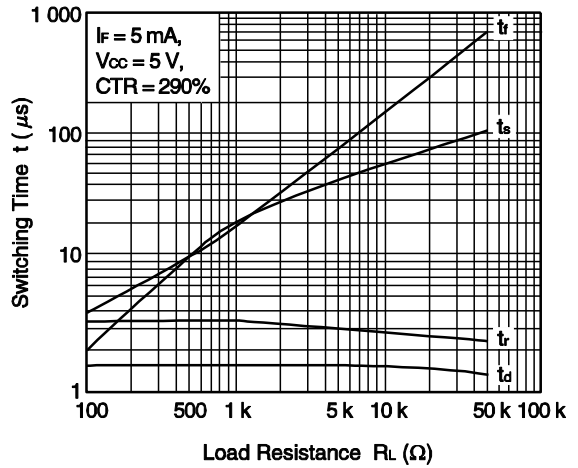

FREQUENCY RESPONSE

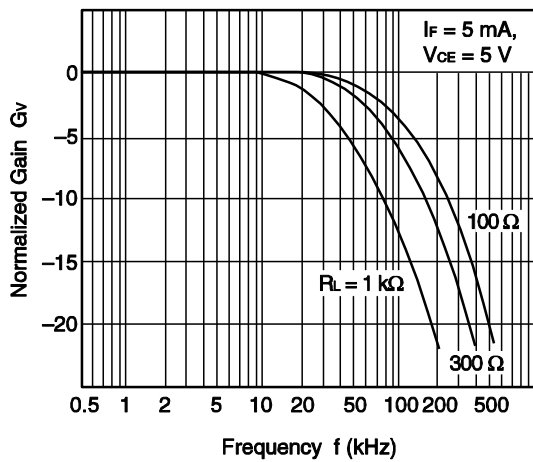

LONG TERM CTR DEGRADATION

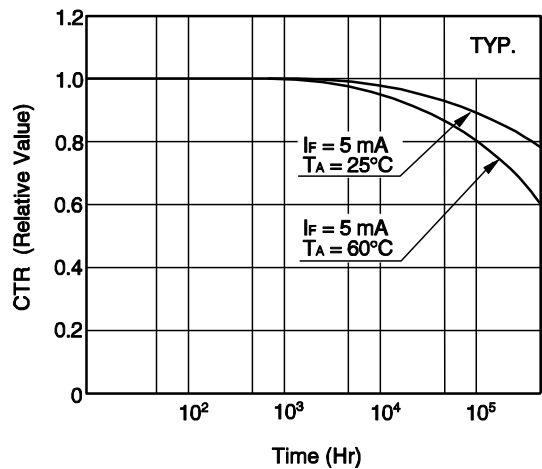

Remark The graphs indicate nominal characteristics.

TAPING SPECIFICATIONS (UNIT : mm)

Outline and Dimensions (Tape)

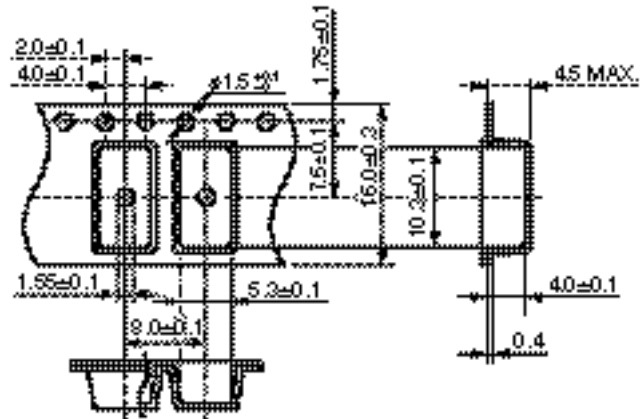

Tape Direction

PS2561L-1-E3

PS2561L-1-E4

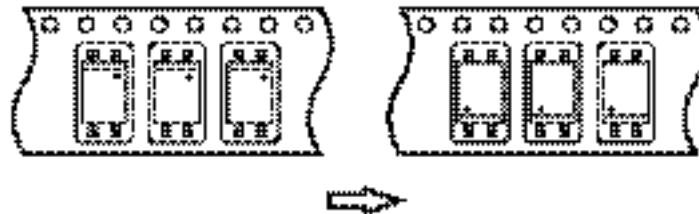

Outline and Dimensions (Reel)

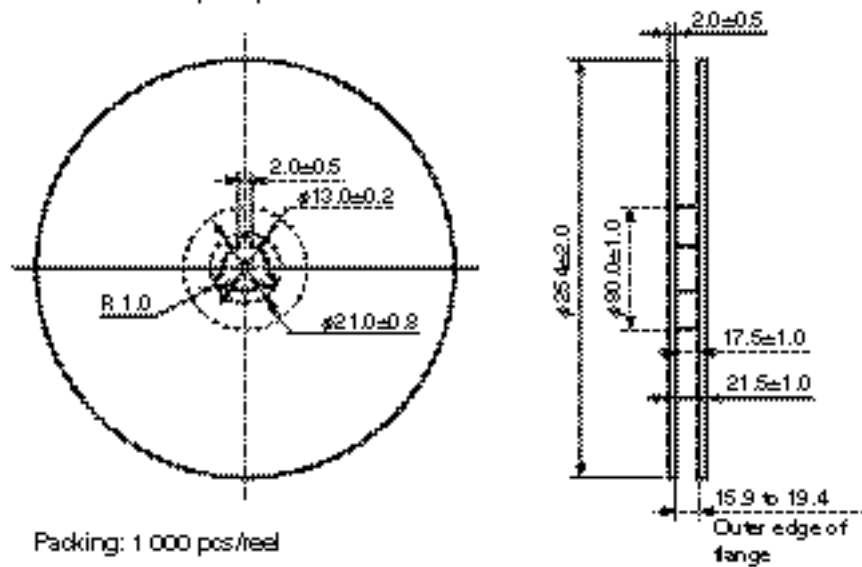

Outline and Dimensions (Tape)

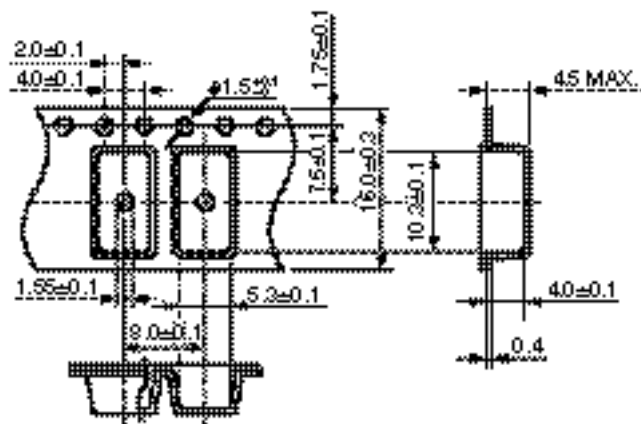

Tape Direction

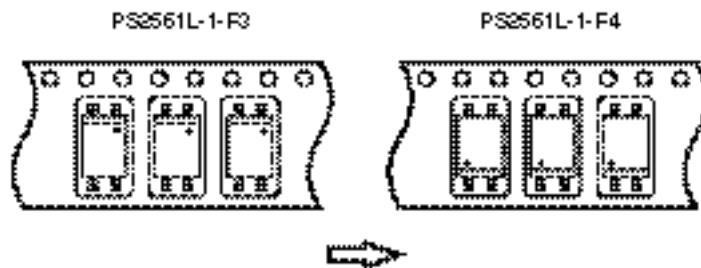

Outline and Dimensions (Reel)

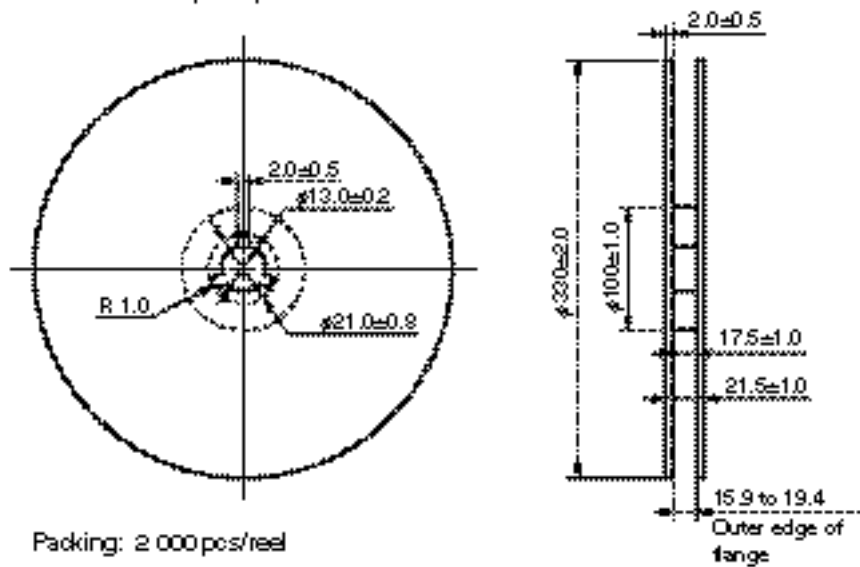

Outline and Dimensions (Tape)

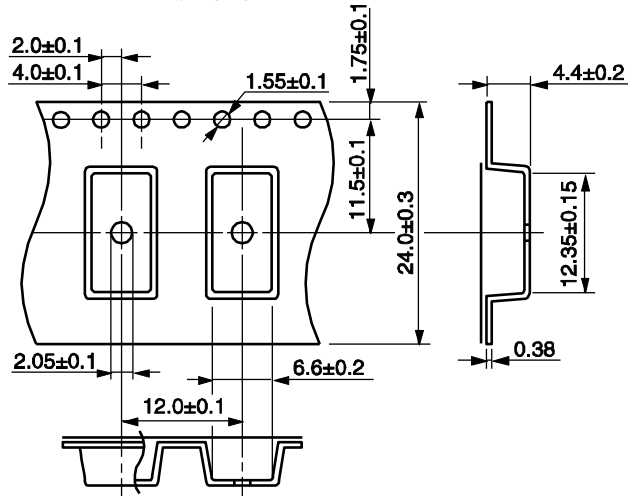

Tape Direction

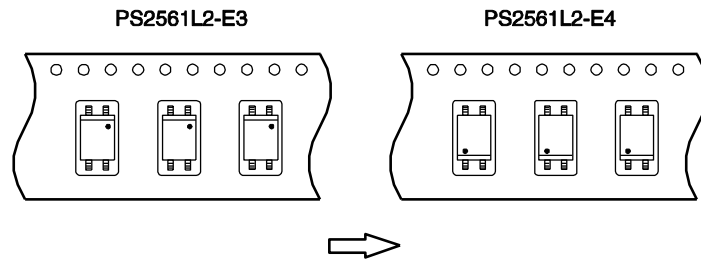

Outline and Dimensions (Reel)

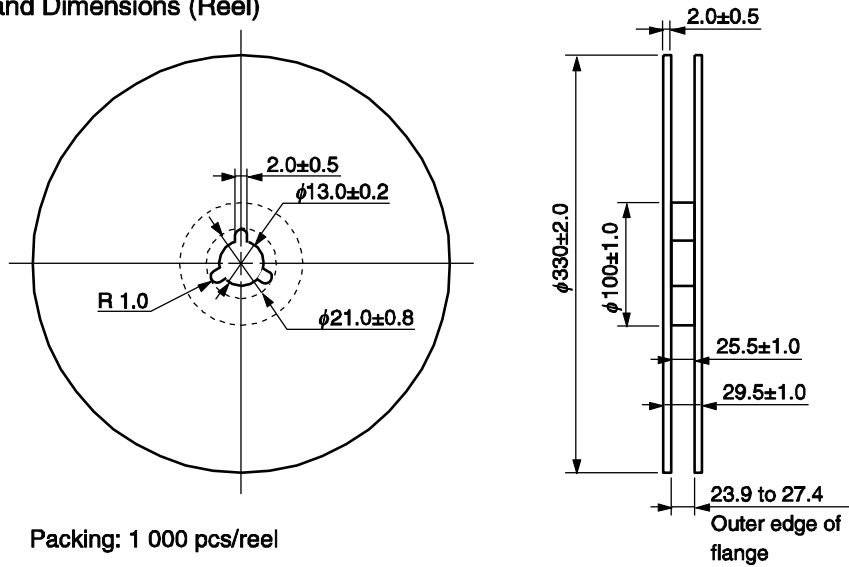

NOTES ON HANDLING

1. Recommended soldering conditions

(1) Infrared reflow soldering

- Peak reflow temperature 260°C or below (package surface temperature)
- Time of peak reflow temperature 10 seconds or less
- Time of temperature higher than 220°C 60 seconds or less
- Time to preheat temperature from 120 to 180°C 120±30 s
- Number of reflows Three
- Flux Rosin flux containing small amount of chlorine (The flux with a maximum chlorine content of 0.2 Wt% is recommended.)

Recommended Temperature Profile of Infrared Reflow

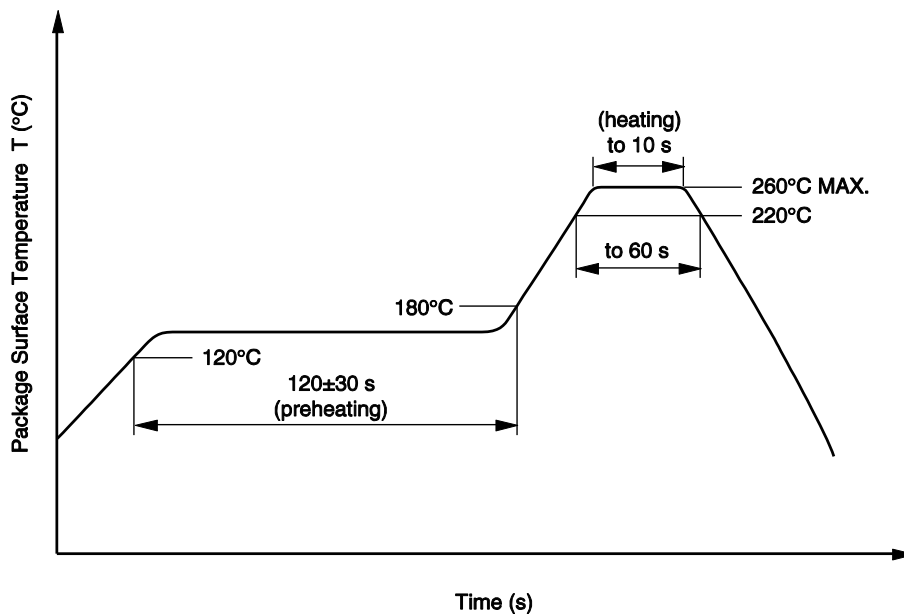

(2) Wave soldering

- Temperature 260°C or below (molten solder temperature)
- Time 10 seconds or less
- Preheating conditions 120°C or below (package surface temperature)
- Number of times One (Allowed to be dipped in solder including plastic mold portion.)
- Flux Rosin flux containing small amount of chlorine (The flux with a maximum chlorine content of 0.2 Wt% is recommended.)

(3) Soldering by soldering iron

- Peak temperature (lead part temperature) 350°C or below
- Time (each pins) 3 seconds or less
- Flux Rosin flux containing small amount of chlorine (The flux with a maximum chlorine content of 0.2 Wt% is recommended.)

- (a) Soldering of leads should be made at the point 1.5 to 2.0 mm from the root of the lead.
- (b) Please be sure that the temperature of the package would not be heated over 100°C.

(4) Cautions

- Fluxes

Avoid removing the residual flux with freon-based and chlorine-based cleaning solvent.

2. Cautions regarding noise

Be aware that when voltage is applied suddenly between the photocoupler's input and output or between collector-emitters at startup, the output transistor may enter the on state, even if the voltage is within the absolute maximum ratings.

3. Measurement conditions of current transfer ratios (CTR), which differ according to photocoupler

Check the setting values before use, since the forward current conditions at CTR measurement differ according to product.

When using products other than at the specified forward current, the characteristics curves may differ from the standard curves due to CTR value variations or the like. This tendency may sometimes be obvious, especially below $I_F = 1$ mA.

Therefore, check the characteristics under the actual operating conditions and thoroughly take variations or the like into consideration before use.

USAGE CAUTIONS

1. Protect against static electricity when handling.
2. Avoid storage at a high temperature and high humidity.

<R> **SPECIFICATION OF VDE MARKS LICENSE DOCUMENT**

| Parameter | Symbol | Spec. | Unit |
|--|--|-----------------------------|----------------------------|
| Climatic test class (IEC 60068-1/DIN EN 60068-1) | | 55/100/21 | |
| Dielectric strength maximum operating isolation voltage Test voltage (partial discharge test, procedure a for type test and random test) $U_{pr} = 1.5 \times U_{IORM}, P_d < 5 \text{ pC}$ | U_{IORM} U_{pr} | 890 1 335 | V_{peak} V_{peak} |
| Test voltage (partial discharge test, procedure b for all devices) $U_{pr} = 1.875 \times U_{IORM}, P_d < 5 \text{ pC}$ | U_{pr} | 1 669 | V_{peak} |
| Highest permissible overvoltage | U_{TR} | 8 000 | V_{peak} |
| Degree of pollution (DIN EN 60664-1 VDE0110 Part 1) | | 2 | |
| Clearance distance | | >7.0 | mm |
| Creepage distance | | >7.0 | mm |
| Comparative tracking index (IEC 60112/DIN EN 60112 (VDE 0303 Part 11)) | CTI | 175 | |
| Material group (DIN EN 60664-1 VDE0110 Part 1) | | III a | |
| Storage temperature range | T_{stg} | -55 to +150 | °C |
| Operating temperature range | T_A | -55 to +100 | °C |
| Isolation resistance, minimum value $V_{IO} = 500 \text{ V dc at } T_A = 25^\circ\text{C}$ $V_{IO} = 500 \text{ V dc at } T_A \text{ MAX. at least } 100^\circ\text{C}$ | Ris MIN. Ris MIN. | 10^{12} 10^{11} | Ω Ω |
| Safety maximum ratings (maximum permissible in case of fault, see thermal derating curve) Package temperature Current (input current I_F , $P_{si} = 0$) Power (output or total power dissipation) Isolation resistance $V_{IO} = 500 \text{ V dc at } T_A = T_{si}$ | T_{si} I_{si} P_{si} Ris MIN. | 175 400 700 10^9 | °C mA mW Ω |

- **The information in this document is current as of December, 2008. The information is subject to change without notice. For actual design-in, refer to the latest publications of NEC Electronics data sheets or data books, etc., for the most up-to-date specifications of NEC Electronics products. Not all products and/or types are available in every country. Please check with an NEC Electronics sales representative for availability and additional information.**
- No part of this document may be copied or reproduced in any form or by any means without the prior written consent of NEC Electronics. NEC Electronics assumes no responsibility for any errors that may appear in this document.
- NEC Electronics does not assume any liability for infringement of patents, copyrights or other intellectual property rights of third parties by or arising from the use of NEC Electronics products listed in this document or any other liability arising from the use of such products. No license, express, implied or otherwise, is granted under any patents, copyrights or other intellectual property rights of NEC Electronics or others.
- Descriptions of circuits, software and other related information in this document are provided for illustrative purposes in semiconductor product operation and application examples. The incorporation of these circuits, software and information in the design of a customer's equipment shall be done under the full responsibility of the customer. NEC Electronics assumes no responsibility for any losses incurred by customers or third parties arising from the use of these circuits, software and information.
- While NEC Electronics endeavors to enhance the quality, reliability and safety of NEC Electronics products, customers agree and acknowledge that the possibility of defects thereof cannot be eliminated entirely. To minimize risks of damage to property or injury (including death) to persons arising from defects in NEC Electronics products, customers must incorporate sufficient safety measures in their design, such as redundancy, fire-containment and anti-failure features.
- NEC Electronics products are classified into the following three quality grades: "Standard", "Special" and "Specific".

The "Specific" quality grade applies only to NEC Electronics products developed based on a customer-designated "quality assurance program" for a specific application. The recommended applications of an NEC Electronics product depend on its quality grade, as indicated below. Customers must check the quality grade of each NEC Electronics product before using it in a particular application.

"Standard": Computers, office equipment, communications equipment, test and measurement equipment, audio and visual equipment, home electronic appliances, machine tools, personal electronic equipment and industrial robots.

"Special": Transportation equipment (automobiles, trains, ships, etc.), traffic control systems, anti-disaster systems, anti-crime systems, safety equipment and medical equipment (not specifically designed for life support).

"Specific": Aircraft, aerospace equipment, submersible repeaters, nuclear reactor control systems, life support systems and medical equipment for life support, etc.

The quality grade of NEC Electronics products is "Standard" unless otherwise expressly specified in NEC Electronics data sheets or data books, etc. If customers wish to use NEC Electronics products in applications not intended by NEC Electronics, they must contact an NEC Electronics sales representative in advance to determine NEC Electronics' willingness to support a given application.

(Note)

- (1) "NEC Electronics" as used in this statement means NEC Electronics Corporation and also includes its majority-owned subsidiaries.
- (2) "NEC Electronics products" means any product developed or manufactured by or for NEC Electronics (as defined above).

| | | |
|-----------------------|----------------------|---|
| <p>Caution</p> | <p>GaAs Products</p> | <p>This product uses gallium arsenide (GaAs). GaAs vapor and powder are hazardous to human health if inhaled or ingested, so please observe the following points.</p> <ul style="list-style-type: none"> • Follow related laws and ordinances when disposing of the product. If there are no applicable laws and/or ordinances, dispose of the product as recommended below. <ol style="list-style-type: none"> 1. Commission a disposal company able to (with a license to) collect, transport and dispose of materials that contain arsenic and other such industrial waste materials. 2. Exclude the product from general industrial waste and household garbage, and ensure that the product is controlled (as industrial waste subject to special control) up until final disposal. • Do not burn, destroy, cut, crush, or chemically dissolve the product. • Do not lick the product or in any way allow it to enter the mouth. |
|-----------------------|----------------------|---|